



PRESSES & SHEARS FOR METAL SCRAP PROCESSING

Static Press CRASH BALER 5.0 MAX



Main qualities that distinguish it:

- ✓ Quick compaction
- ✓ Speed in parcel execution
- ✓ Easy to use
- ✓ Robustness of the structure
- ✓ Low fuel consumption
- ✓ Low operating costs

Armatek s.r.l.
Sede legale:
Via Lungotevere, Ripa n° 3/B
c.a.p. 00153 - Roma - Italy

Stabilimento / uffici:
C. da Santa Maria Ingrisone
82010 - San Nicola Manfredi
Benevento- Italy

n° REA : RM-1497036
P. Iva / C.F. : IT14098221006
Cap. soc. € 32.500,00 i.v.
Codice Univoco 5RU082D

Tel. +39.392.9771395
www.armacrecycling.com
armateksrl@gmail.com
pec : armac.tek@pec.it



PRESSES & SHEARS FOR METAL SCRAP PROCESSING

Possible Configuration:



STANDARD VERSION



EJECTION DOOR



HYDRAULIC LEGS



EJECTION DOOR WITH LEGS

Armatek s.r.l.
Sede legale:
Via Lungotevere, Ripa n° 3/B
c.a.p. 00153 - Roma - Italy

Stabilimento / uffici :
C. da Santa Maria Ingrisone
82010 - San Nicola Manfredi
Benevento- Italy

n° REA : RM-1497036
P. Iva / C.F. : IT14098221006
Cap. soc. € 32.500,00 i.v.
Codice Univoco 5RU082D

Tel. +39.392.9771395
www.armacrecycling.com
armateksrl@gmail.com
pec : armac.tek@pec.it



PRESSES & SHEARS FOR METAL SCRAP PROCESSING

Some differences that distinguish us:



Possibility of loading with forklift



Easy unloading with material handler



Large charging box



High compaction force



PRESSES & SHEARS FOR METAL SCRAP PROCESSING

CRASH BALER 5.0 MAX

Technical Data

TECHNICAL SPECIFICATIONS :

ENGINE TYPE	DIESEL 4 CIL WATER COOLING
ENGINE BRAND	FPT – CNH Group
POWER INSTALLATION	103 Kw /140 Cv Stage 3
DIESEL INJECTION TYPE	COMMON-RAIL
ELECTRIC PLANT	PLC SYSTEM
SYSTEM CONTROL	REMOTE RADIO CONTROL
DIESEL TANK CAPACITY	Lt 100
HYDRAULIC OIL TANK CAPACITY	Lt 800
HYDRAULIC OIL PLANT CAPACITY	Lt 1.000
HYDRAULIC PUMPS TYPE	VIARABLE FLOW PUMP + GEAR PUMP
HYDRAULIC OIL COOLER	ELECTRIC RADIATOR
BOX MATERIAL CONSTRUCTION	HARDOX 450
BALE SIZE	mm. 900 x 700 x variabile
CYLINDER VERTICAL DOOR	N° 02
CYLINDER SIDE MOVABLE WALL	N° 02
CYCLE TIME	1 min. 45 sec.(+ 20 sec e.d.)
PRODUCTION WITH CARS	13-25 t/h
PRODUCTION WITH METAL SCRAP	20-28 t/h
AUTOMATIC CYCLE	INCLUDED
RADIO CONTROL	INCLUDED
LARGER RADIO ANTENNA	INCLUDED
REMOTE ASSISTANCE CONTROL	INCLUDED
EJECTION DOOR	OPTIONAL
HYDRAULIC LEGS	OPTIONAL

Armatek s.r.l.

Sede legale:

Via Lungotevere, Ripa n° 3/B
c.a.p. 00153 - Roma - Italy

Stabilimento / uffici:

C. da Santa Maria Ingrisone
82010 - San Nicola Manfredi
Benevento- Italy

n° REA : RM-1497036

P. Iva / C.F. : IT14098221006

Cap. soc. € 32.500,00 i.v.

Codice Univoco 5RU082D

Tel. +39.392.9771395

www.armacrecycling.com

armateksrl@gmail.com

pec : armac.tek@pec.it



PRESSES & SHEARS FOR METAL SCRAP PROCESSING

CRASH BALER 5.0 MAX

Technical data

SIDE VIEW :

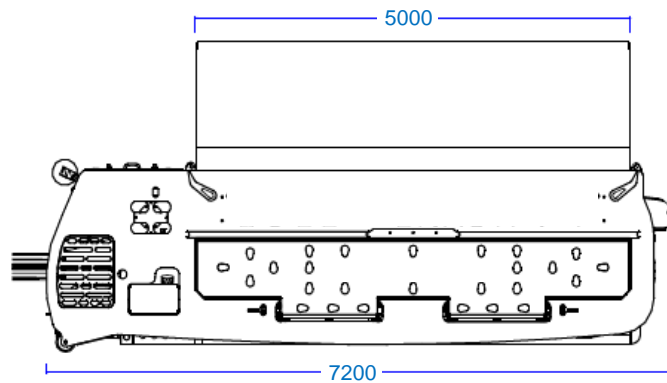

FRONT VIEW :

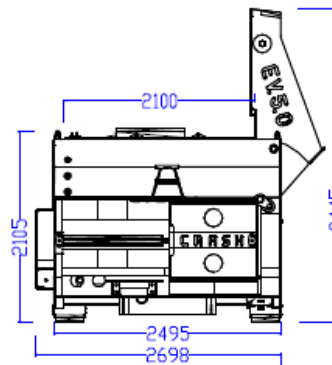

DIMENSIONS :

OVERALL DIMENSION FOR TRANSPORT	mm. 7.200 x 2.495 x 2.115 h
MAX DIMENSION IN WORK PHASE	mm. 10.550 x 3.250 x 3.445 h
BOX DIMENSION	mm. 5.000 x 2.100 x 1.600 h
BALE DIMENSION	mm. 900 x 700 x variabile
TOTAL WEIGHT	Kg. 23.000

Armatek s.r.l.

Sede legale :
Via Lungotevere, Ripa n° 3/B
c.a.p. 00153 - Roma - Italy

Stabilimento / uffici :
C. da Santa Maria Ingrisone
82010 - San Nicola Manfredi
Benevento- Italy

n° REA : RM-1497036
P. Iva / C.F. : IT14098221006
Cap. soc. € 32.500,00 i.v.
Codice Univoco 5RU082D

Tel. +39.392.9771395
www.armarecycling.com
armateksrl@gmail.com
pec : armac.tek@pec.it